

Predominant clonal evolution leads to a close parity between gene expression profiles and subspecific phylogeny in *Trypanosoma cruzi*

Jenny Telleria, Christian Barnabé, Mallorie Hide, Anne-Laure Bañuls, Michel Tibayrenc*

Génétique et Evolution des Maladies Infectieuses, Unité Mixte de Recherche 2724 Centre National de la Recherche Scientifique (CNRS)/Institut de Recherche pour le Développement (IRD) BP64501, 34394 Montpellier Cedex 05, France

Received 20 January 2004; received in revised form 13 February 2004; accepted 3 May 2004

Available online 19 June 2004

Abstract

We investigated the relationships between overall phylogenetic diversity in *Trypanosoma cruzi* evidenced by multilocus markers (MLEE and RAPD) on the one hand, and gene expression patterns, revealed by mRNA analysis on the other hand. Nineteen laboratory-cloned stocks representative of this parasite's overall phylogenetic diversity and ecogeographical range were analyzed using random amplified differentially expressed sequences (RADES). The bat trypanosome *T. cruzi marinkellei* was taken as outgroup. The profiles obtained showed that RADES polymorphism cannot be considered as a simple subsample of general RAPD polymorphism. Indeed, many RADES bands were not present in general RAPD profiles, and vice versa. Phylogenies obtained from RADES on the one hand, and MLEE/RAPD on the other hand, were very similar. This suggests that in spite of the recent observation of hybrid genotypes and mosaic genes in *T. cruzi*, clonal evolution in this parasite has been preponderant enough on an evolutionary scale to carve the polymorphism on all types of DNA sequences, including expressed genes, although these genes are assumed to undergo natural selection pressure contrary to noncoding sequences and neutral polymorphisms.

© 2004 Elsevier B.V. All rights reserved.

Keywords: Chagas disease; *Trypanosoma cruzi*; Phylogeny; Horizontal gene transfert; Recombination; Mosaic gene

1. Introduction

Trypanosoma cruzi is the flagellate protozoon responsible for Chagas disease in Latin America and southern USA. In the USA, native cases are exceptional, whereas several million people are at risk in Latin America.

The analysis of *T. cruzi* genetic variability in terms of population genetics led to the hypothesis that this parasite's natural populations undergo predominant clonal evolution with at best rare genetic exchange [1]. *T. cruzi* natural clones are divided into two main genetic subdivisions [2,3], which were subsequently referred to as *T. cruzi* I and *T. cruzi* II (TC I and II) [4]. TC II is further subdivided into five lesser clusters, for a total of six distinguishable subdivisions [5,6]. Although they are clearly delimited, these subdivisions can-

not be equated with real clades, because there are some genetic exchange and genotypes of hybrid origin (see below). These subdivisions have been referred to as discrete typing units or DTUs [7]. DTU I corresponds to TC I, and DTU II corresponds to TC II. DTU II's lesser subdivisions are II a, II b, II c, II d and II e [5].

Several studies have reported the existence of recombinant genotypes in this species, either in natural populations [8–10] or in experiments [11]. Based on these results, the clonal model has been explicitly challenged [12].

However, the two proposals are not inconsistent with each other. Actually, the model proposed for various major parasitic protozoan species within clonal theory [13] does not state that recombination is absent, but rather that it is not frequent enough to break the prevalent pattern of the clonal population structure. However, the debate is again open [12] on the impact of clonal evolution and genetic exchange in *T. cruzi* natural populations.

An expected consequence of long-term clonal evolution is an agreement between phylogenetic trees built from independent genetic markers. Such a parity has been observed in *T. cruzi* between multilocus enzyme electrophoresis (MLEE)

Abbreviations: DTU, discrete typing unit; MLEE, multilocus enzyme electrophoresis; Myr, millions of years; RADES, random amplified differentially expressed sequences; RAPD, random amplified polymorphic DNA

* Corresponding author. Tel.: +33 4 67 41 62 07; fax: +33 4 67 41 62 99.

E-mail address: Michel.Tibayrenc@mpl.ird.fr (M. Tibayrenc).

and random amplified polymorphic DNA (RAPD) [5,6,14]. After being the topic of many studies looking for natural selection on allozymes in the 70', MLEE variability is now considered to be nearly neutral [15], whereas RAPD explores various parts of the genome, of which many correspond to noncoding sequences. The results of the *T. cruzi* genome project suggest that there are 50% coding and 50% noncoding sequences in this parasite's genome (El-Sayed, personal communication). In predominant clonal evolution, a correlation between MLEE and RAPD phylogenies is therefore not unexpected. Coding regions could exhibit a different pattern, since they directly govern phenotypic polymorphism. They are therefore bound to be under selective pressure, and far from a pattern of random accumulation of mutations. In this study, we analyzed the polymorphism of gene expression in *T. cruzi* and have compared it to MLEE and RAPD phylogenies. Gene expression was surveyed through the analysis of messenger RNA (mRNA).

2. Material and methods

2.1. *T. cruzi* stocks

The 19 stocks used for this study are described in Table 1. They correspond to a standardized set of stocks that has been used for many studies in our laboratory. As ascertained by previous studies relying on the analysis of more than 450 stocks [5], they can be considered as a representative subsample of the entire genetic diversity and ecogeographical range of *T. cruzi*. They include stocks attributed to the six genetic subdivisions of this parasite, or discrete typing units (DTUs) [5–7]. All these stocks were cloned in the labora-

tory by micromanipulation under the microscope. The stocks were cultivated in RPMI-1640 (FBS 20%, glutamine 1%).

The identity of the genotypes of the 19 stocks under study was checked just prior to the study with six isoenzyme systems: diaphorase (EC 1.6.99.2, DIA), glutamate dehydrogenase NADP+ (GDH, EC 1.4.1.4), glucose phosphate isomerase (GPI, EC 5.3.1.9), isocitrate dehydrogenase (IDH, EC 1.1.1.42), malate dehydrogenase NADP+ or malic enzyme (ME, 1.1.1.40) and phosphogluconate dehydrogenase (6PGD, EC 1.1.1.44).

2.2. Preparation and amplification of cDNA

Messenger RNAs were isolated by a technique derived from the RADES (random amplified differentially expressed sequences) technique [16]. The mRNA was isolated by magnetic beads (Dynabeads) 2.8 µm in diameter, tailed by poly(dT) (dT25 nt). The poly(A)RNA captured by poly(dT) tail was eluted in 20 µl of RNase-free water. The mRNA was quantified by spectrometry at 260 nm.

The reverse transcription was achieved by AMV reverse transcriptase (15 U/µg of mRNA (Promega), using oligo(dT) primer (dT18nt), in the presence of dNTP and with a ribonuclease inhibitor (RNasin). The mixture was incubated at 42 °C for 60 mn. The QIA quick PCR purification kit [Qiagen], which eliminates oligonucleotides of less than 40 nt, was used to purify the cDNA. The purified cDNA was quantified at 260 nm.

The quantity of cDNA obtained by reverse transcription was insufficient to be amplified by various RAPD primers (random amplified polymorphic DNA) [17]. Consequently, it was necessary to previously amplify the cDNA by PCR, using two primers, a 23-nt primer based on the conserved

Table 1

List, origin and genetic identification (DTU) of the 19 *Trypanosoma cruzi* and 2 *T. cruzi marinkellei* stocks analyzed in the present study

Species (no. of stock)	Code	DTU	Host	Country	Locality
<i>T. cruzi</i> (1)	Cutia C11	I	<i>Dasyprocta aguti</i>	Brazil	Espiritu Santo, Colatina
<i>T. cruzi</i> (2)	SP 104 c11	I	<i>Triatoma spinolai</i>	Chile	Region IV, Combarbala
<i>T. cruzi</i> (3)	P 209 c193	I	Human	Bolivia	Sucre
<i>T. cruzi</i> (4)	92122102R	II a	<i>Procyon lotor</i>	USA	Georgia, Statesboro, Bulloch
<i>T. cruzi</i> (5)	CanIII c11 z3	II a	Human	Brazil	Bèlem
<i>T. cruzi</i> (6)	Tu 18 cl 93	II b	<i>Triatoma infestans</i>	Bolivia	Tupiza
<i>T. cruzi</i> (7)	CBB cl 3	II b	Human	Chile	Region IV, Tulahuèn
<i>T. cruzi</i> (8)	Mas cl 1	II b	Human	Brazil	Brasilia
<i>T. cruzi</i> (9)	Ivv cl4	II b	Human	Chile	Region IV, Cuncumen
<i>T. cruzi</i> (10)	CM17	II c	<i>Dasyptes sp.</i>	Colombia	Meta, Carimaga
<i>T. cruzi</i> (11)	M 5631 cl3	II c	<i>Didelphis novemcinctus</i>	Brazil	Selva Terra
<i>T. cruzi</i> (12)	M 6241 cl6	II c	Human	Brazil	Belen
<i>T. cruzi</i> (13)	MN cl 2	II d	Human	Chile	Region IV, Llapel
<i>T. cruzi</i> (14)	Bug2148 cl1	II d	<i>Triatoma infestans</i>	Brazil	Rio Grande do Sul
<i>T. cruzi</i> (15)	SO 3 cl5	II d	<i>Triatoma infestans</i>	Bolivia	Potosi
<i>T. cruzi</i> (16)	Sc 43 cl1	II d	<i>Triatoma infestans</i>	Bolivia	Santa cruz
<i>T. cruzi</i> (17)	CL Brener	II e	<i>Triatoma infestans</i>	Brazil	Rio Grande do Sul
<i>T. cruzi</i> (18)	P63 cl1	II e	<i>Triatoma infestans</i>	Paraguay	Makthlawaiya
<i>T. cruzi</i> (19)	Tula cl2	II e	Human	Chile	Region IV, Tulahuèn
<i>T. cruzi marinkellei</i>	B3	–	<i>Phyllostomum discolor</i>	Brazil	Bahia, São Felipe
<i>T. cruzi marinkellei</i>	M109	–	<i>Phyllostomum discolor</i>	Venezuela	Caracas

mini-exon sequence, and an 18-nt oligo dT primer (dT 18) complementary to the 3' end. This mini-exon or spliced leader (SL) exhibits a conserved sequence of 39 nt at the 5' end on all mature Trypanosomatidae mRNA [18]. We performed a bi-directional amplification on 30 ng of cDNA, in a final volume of 30 μ l containing 3 μ l buffer (MgCl₂ 1.5 mM, KCl 50 mM, Tris-HCl 10 mM, pH 8.3), dNTP 0.8 mM, 0.6 μ M of each primer, and 1 U of Taq polymerase (Roche). The PCR cycle was 2 mn at 94 °C, 1.5 mn at 61 °C, and 3 mn at 72 °C, then 10 cycles of 30 s at 94 °C, 1.5 mn at 61 °C, 3 mn 72 °C, followed by 25 cycles of 30 s at 94 °C, 1.5 mn at 45 °C, 3 mn at 72 °C, with a final extension step of 5 mn at 72 °C.

2.3. Polymorphism revealed by RAPD

The RAPD technique amplifies DNA using short primers, usually 10 base pairs long, whose sequence is arbitrarily selected and randomly hybridizes throughout the genome [17]. This technique may detect polymorphisms generated by either point mutations in the matching site or deletions/insertions. Out of many primers previously tested [6,14], we selected 17 corresponding to the A, B, E, F, N, R and U kits from Operon Technologies (Alameda, CA). These primers were retained because they gave us the most readable and reproducible results, as checked by at least two different assays. We amplified 20 ng of purified *T. cruzi* DNA in a final volume of 60 μ l, with a program standardized in our laboratory. It is based on 45 cycles of 1 mn at 94 °C, 1 mn at 36 °C, 2 mn at 72 °C, followed by a final elongation step of 7 mn at 72 °C. The PCR products were separated by electrophoresis on 1.6% agarose gels in 0.5 \times TAE buffer (Tris-Acetate 40 mM, EDTA 1 mM, pH 8.0) at 100 V for 30 mn. The gels were stained with 0.5 μ g/ml ethidium bromide and visualized under UV exposure.

2.4. Data analysis

Genetic divergences between the stocks were estimated with Jaccard's genetic distance [19]. Each RAPD and RADES gel band was coded with a number, starting with 1 for the heaviest band. The following formula was used: $D_j = 1 - a/(a + b + c)$, where a is the number of bands that are common to the two compared genotypes, b is the number of bands present in the first genotype and absent in the second, and c is the number of bands absent in the first genotype and present in the second.

Genetic relationships among the stocks were estimated by the unweighted pair-group method with arithmetic averages (UPGMA) [20] and by the neighbor-joining method [21]. Jaccard's genetic distances were calculated using the Genetics ToolBox software developed in our laboratory. The Neighbor software from the PHYLIP package [22] was used to build UPGMA and NJ trees, which were visualized with the Tree view software [23]. Robustness of the phylogenetic MP trees (maximum parsimony trees)

was estimated by bootstrap analysis [24], using the appropriate software, which is included in PHYLIP (seqboot, mix and consense). Agreement between genetic distances computed from MLEE, RAPD data and RADES data (G test) [13] were tested by correlation analysis based on the nonparametric Mantel test [25] using the genetics software designed in our laboratory. Contrary to a classic correlation test, this randomization procedure requires no assumptions on the number of degrees of freedom. The test was performed by a Montecarlo simulation based on 10⁴ iterations [13]. This randomization test was performed on the *T. cruzi* stocks only. Outgroups were excluded from the analysis. For MLEE data, we took the genetic distance values based on 22 isoenzyme loci for the same set of stocks [5].

3. Results

3.1. RAPD and RADES analysis

RAPD (Fig. 1a) and RADES (Figs. 1b and 2) multiband profiles obtained by PCR with 17 primers showed substantial genetic polymorphism, highly related within the stocks of the same DTU, but also demonstrated differences between stocks belonging to different DTUs. Table 2 lists all multiband patterns obtained for the 17 primers with RAPD and RADES. For a given primer, a given multiband pattern is equated with a distinct genotype whose allelic composition is unknown [13]. In population genetic analyses, it is processed as a single locus, although the involved primer may have amplified several parts of the genome. However, it is generally assumed that distinct primers will amplify distinct parts of the genome [17], which is needed for population genetics analysis [13,14]. Table 2 clearly shows that RAPD and RADES polymorphisms are generally very different. For example, in DTU I, the A2 primer shows two bands for RAPD, and only one, with a quite different migration, for RADES. For the same primer, in DTU II b, the RADES pattern is much more complex (five bands) than the RAPD pattern (only one band). Many bands observed with RAPD amplification were not seen in RADES profiles and vice versa, which means that most RADES genotypes were specific for this technique and were different from the corresponding RAPD genotypes (Table 2 and Fig. 2).

3.2. Phylogenetic analyses

Using two *T. cruzi marinkellei* stocks as the outgroup, all the phylogenetic trees clustered the stocks in a similar way, whatever the marker used, MLEE, RAPD or RADES, and whatever the method used, either UPGMA or the neighbor-joining tree (see Fig. 3). The robustness of the clustering was corroborated by using a bootstrap procedure that showed significant values (>0.80) for the clusters identifying the DTUs. Phylogenetic analysis revealed a close similarity for the clustering patterns recorded from (i)

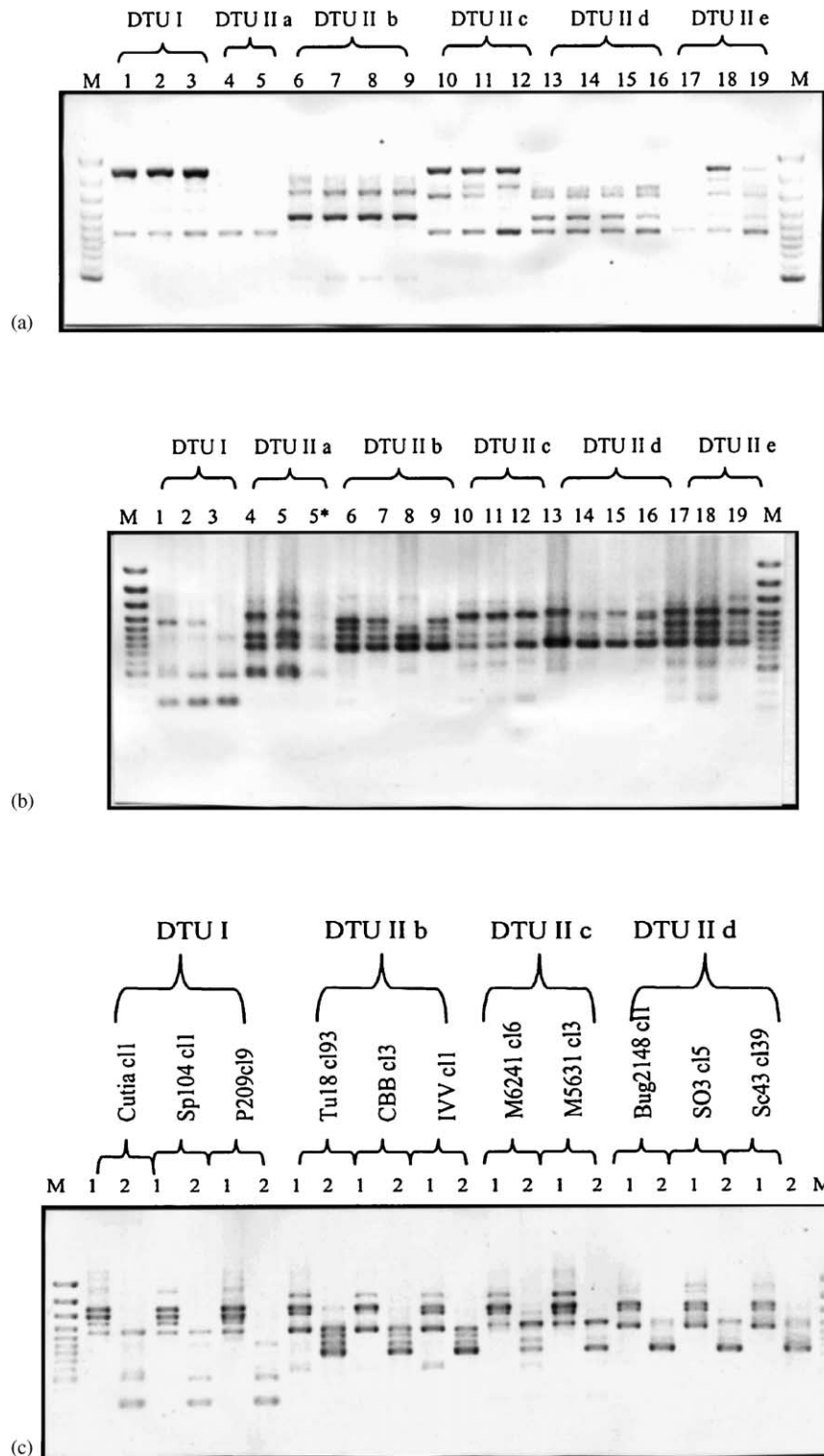

Fig. 1. (a) Amplification patterns of the 19 *Trypanosoma cruzi* stocks, obtained by RAPD analysis with the A9 primer. (b) Amplification patterns obtained by RADES analysis with the B18 primer. Each number corresponds to a *T. cruzi* stock (see Table 1). The groups correspond to the different discrete typing units (DTUs) surveyed in the present work. Lanes marked with M correspond to the DNA molecular weight marker. The stock 5* was not analyzed in the present study. (c) Comparison of RAPD and RADES amplification patterns obtained with the B18 primer: position 1, RAPD pattern, position 2, RADES pattern, lanes marked with M correspond to the DNA molecular weight marker.

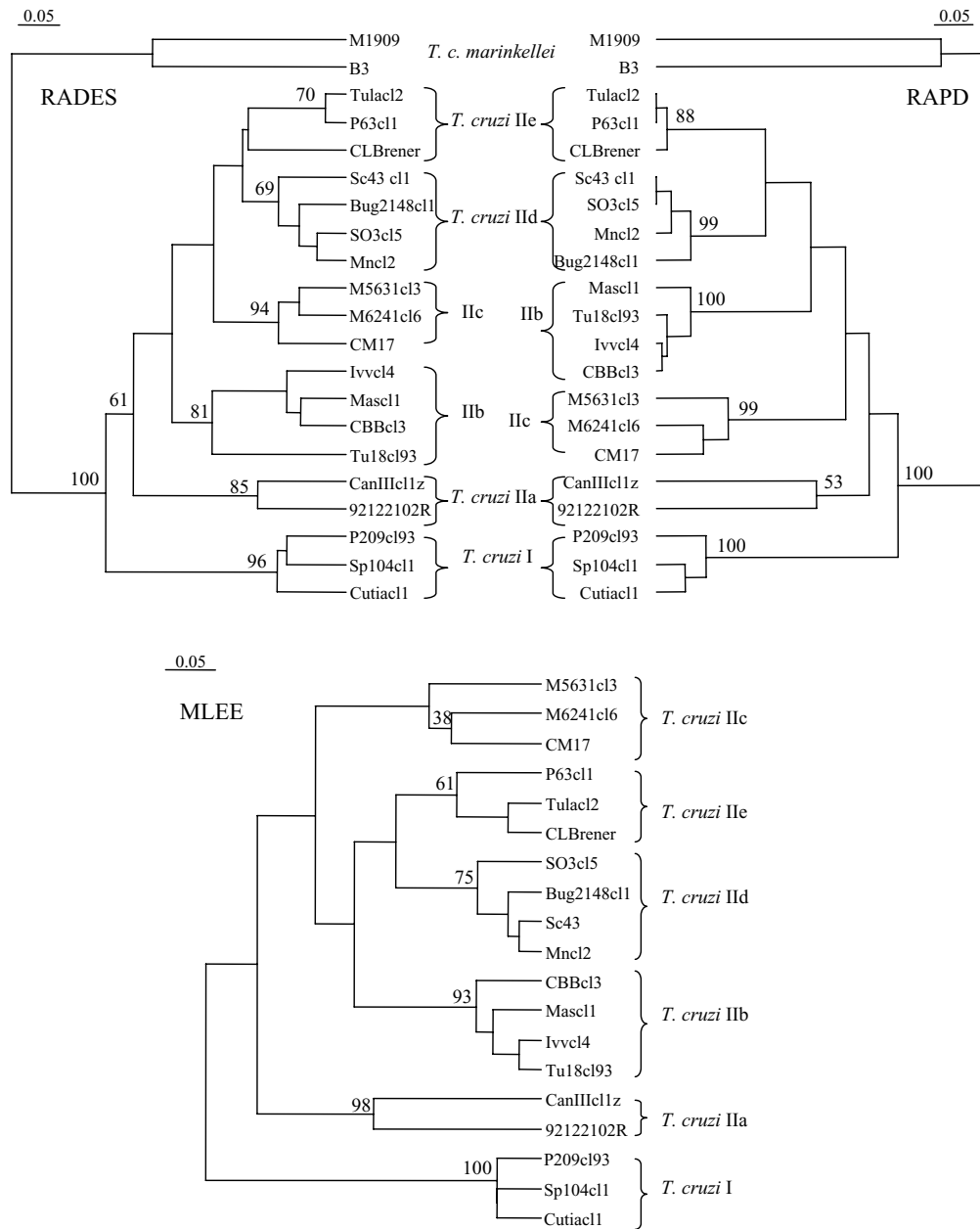

Fig. 2. UPGMA dendrograms built from Jaccard's genetic distances recorded from RAPD data (right), RADES data (left) and MLEE (below), clustering the 19 *Trypanosoma cruzi* stocks surveyed in the present work. The numbers at the nodes indicate the Bootstrap value of each DTU.

MLEE and RAPD; (ii) MLEE and RADES, and (iii) RAPD and RADES. Fig. 3 compares RAPD, RADES and MLEE trees. Results of the *G* tests of correlation between all pairs of markers [13], assayed by the non-parametric Mantel test [25], were all highly significant ($P < 10^{-4}$): MLEE versus RAPD, MLEE versus RADES, or RAPD versus RADES.

4. Discussion

The proposal that *T. cruzi* exhibits a basically clonal population structure [1] has been challenged [12] on the basis

of convincing results on the presence of genetic exchange in this parasite. Hybrid genotypes were detected in *T. cruzi* natural populations by various genetic markers and gene sequencing [6,8–10]. Moreover, experimental hybrids were obtained from two transgenic parental strains [11]. These studies provided the most important results, by showing an extant ability for genetic exchange. The pattern of *T. cruzi* sexual processes is complex, with genetic exchanges occurring between genetic lines that have been separated for 2–9 Myr [10,11]. Contrary to African trypanosomes [26], meiosis is not involved. Genetic exchanges in *T. cruzi* lead to genome fusions, loss of alleles, polyploidy/aneuploidy

Table 2

Banding patterns obtained from RAPD (M1) and RADES (M2), using 17 decameric primers, for the 19 *Trypanosoma cruzi* stocks analyzed in the present work

DTU	No.	M	A2	A7	A9	A10	E3	B1	B11	B18	F13	N4	N15	R1	R2	R8	R10	U16	U20	
I	1	M1	1-2	1-2-4-8-9	1-6	2-5	2-3-4	1-2	2-3	2-3-4-5	1-2-3-5-8	2-3-6-8-9	1-4-6-9-10	2	2-5	1-2-3-4-5	3	1-4	1-2	
		M2	6	3-4-8-9	6	5-6	4-5-6-7	3-5-6-7	3	5-9-10	6-7-8	8	9	3-5	5	4	4-5	3-4	1-2	
	2	M1	1-2	1-2-4-8-9	1-6	2-5	2-3-4	1-2-3	2-3-4	2-3-4	2-3-4-5	2-3-5-8	3-6-8-9	1-4-6-9-10	2	2-3-5	1-2-3-4-5	3	1-4	1-2
		M2	6	3-4-8-9	6-8	5-6	6	3-5-6-7	3-5	5-9-10	6-7-8	11	9	3-5	5	4	4-5	3-4	1-2	
	3	M1	1-2	1-2-4-8-9	1-6	2-5	2-3-4	1-2-3	2-3-4	2-3-4-5	1-2-3-5-8	3-6-8-9	1-4-6-9-10	2-4	2-5	1-2-3-4-5	3	1-4	1-2	
		M2	6	3-4-8-9	6	5-6	6	3-5-6-7	3-4-5	6-9-10	6-7-8	8-10	9	3-5	5	1-4	4-5	3-4	1-2	
II a	4	M1	2	4-7	2-5	1-2-3	2-4	1-4-5	3-5	2-3-5	2-3-6	6-8-9-10	2-6	2-3-5	2-3-5	1-2	2	2-4	1-2	
		M2	3	3	3-5	0	4-6-7	3-5-6-7	3-4-5	4-6-8-9	6	8-10-11	10	3-6-8	6	3-4	0	4	1-2	
	5	M1	2	4-7	2-5	1-2-3	2-3-6	1-3-5	1	2-3-5	2-3-6	6-9-10	4-6	1-2-5-6	2-3-5	1-2	3	2-4	1-2	
		M2	3	3	3-5	3-5	3-6	3-5-6-7	3-4-5	4-6-8-9	6	8-10-11	8-9-10	3-6-8	6	3-4	3-5	4	1-2	
	II b	6	M1	2	3-6-7	2-4	1-3-4-5	1-2-3-6	2-4-5-7	3-4	2-3-5	2-4-5-6	6-9-10	2-3-4	3	3-6	3-4	1-2	2-4	1-2
			M2	2-3-4-5	6-7	5-7-8	5	5-6	3-4	3-6	2-5-6-7-8	3-6	2-3-6-9-11	8-9-11	3	6	1-2-3-4	0	4	1-2
7		M1	2	3-6-7	2-4	1-3-4-5	1-2-3-6	2-4-5-7	3-4	2-3-5	2-4-5-6	6-9-10	2-3-4	3	3-6	1-3-4	1-2	2-4	1-2	
		M2	2-3-5-6	6-7	5-7	5-6	3-4-5-7	3-6	2-5-6-7-8	3-6	2-10	8-9-11	2-3-4-6	6	6	1-2-3-4-5	3-5	4	1-2	
8		M1	2	3-6-7	2-4	1-3-4-5	1-2-3-6	2-4-5-7	3-4	2-3-5	2-4-5-6	6-9-10	2-3-4	3	2-3-6	1-3-4	2	2-4	1-2	
		M2	2-3-4-5	6-7	5	5-6	6	3-4-5-7	3-4-6	2-5-6-7-8	3-6	2-10	8-9-11	2-3-4-6	6	1-2-3-4-5	3-5	4	1-2	
9	M1	2	3-6-7	2-4	1-3-4-5	1-2-3-6	2-4-5-7	3-4	2-3-5	2-4-5-6	6-9-10	2-3-4	3	3-6	1-3-4	1-2	2-4	1-2		
	M2	2-3-5-6	6-7	5-7	5-6	5-6	3-4-5-7	3-4-6	2-5-6-7-8	3-6	2-3-6-9-12	8-9-11	2-3-4-6	6	1-2-3-4	5	4	1-2		
II c	10	M1	2	3-4-5-6-7	1-2-3-5	3-4-6	2-7	2-4-5	2-4	1-2-3-5	1-3-5-6	1-9-10-12	2-4-5-9-10	1-2-3	1-2-4	1-4	1-2	2-4	1-2	
		M2	4-6	6-7	6	6	3-5-7	5-6	3-4-6	5-8	3-6	3-6-9-12	10	2-4-6	5-6	1-2-3-4	3-4-5	4	1-2	
	11	M1	2	3-4-5-6-7	1-2-3-5	3-4-6	2-7	2-4-5	2-4	1-2-3-5	1-3-5-6	9-10-12	2-4-5-9-10	1-2-3	1-2-4	1-4	1-2	2-4	1-2	
		M2	6	6-7	5-7	6	3-5-7	5-6	3-4-6	5-8	3-6	3-6-9-12	8-9-10	3-5-6	5-6	1-2-3-4	3	4	1-2	
	12	M1	2-6	3-4-5-6-7	1-2-3-5	3-4-6	1-2-7	2-4-5	1-4	1-2-3-5	1-3-5-6	9-10-12	2-4-5-9-10	1-2-3	1-2-3-4-5	1-4	2	2-4	1-2	
		M2	2-6	6-7	5-7	6	3-5-7	5-6	3-4-6	5-8	3-6	3-6-9-12	8-9-10	4-5	5-6	1-2-3-4	3-4-5	4	1-2	
II d	13	M1	2	3-6	3-4-5	6	1-3-6	2-4-5	4	1-2-3-5	3-4-5-6	1-5-9	2-3-5-6-7-10	1-3-5	1-2-3-4	1-3-4	1-2-3	2-4	1-2	
		M2	3-6	6-7	5-7-8	6	4-5-6-7	4-5-6	2-3	5-8	3-6	3-8-10	9-10	3-4-6	4-5-6	2-4	3-5	4	1-2	
	14	M1	2	3-6	3-4-5	6	3-6	2-4-5	4	1-2-3-5	3-4-5-6	1-5-9	2-3-5-6	1-3-5	1-2-3-4	1-3-4	1-2-3	2-4	1-2	
		M2	3-6	6-7	5-7-8	4-5-6	4-5-6-7	4-5-6	2-3	5-8	3-6	3-10	9-10	3-4-6	4-5-6	6	2	4	1-2	
	15	M1	2	3-6	3-4-5	3-4-6	1-3-6	2-4-5	4	1-2-3-5	3-4-5-6	1-5-9	2-3-5-6-7-10	1-3-5	1-2-3-4	1-3-4	1-2-3	2-4	1-2	
		M2	3-6	6-7	5-7-8	4-5-6	4-5-6-7	4-5-6	2-3	5-8	3-6	3-8-10	9-10	3-4-6	4-5-6	4-6	5	4	1-2	
16	M1	2	3-6	3-4-5	3-4-6	1-3-6	2-4-5	4	1-2-3-5	3-4-5-6	1-5-9	2-3-5-6-7-10	1-3-5	1-2-3-4	1-3-4	1-2-3	2-4	1-2		
	M2	3-6	6-7	5-7-8	4-5-6	5-6	4-5-6	2-3	5-8	3-6	3-10	9-10	3-4-6	4-5-6	0	3-5	4	1-2		
II e	17	M1	2	4-6-7	1-2-3-5	3-4-6	1-3-4	2-3-4-5	4	2-5-9	3-5-6	1-8-9	2-4-6	2-3-4	2-3-4	1-3-4-5	3	2-4	1-2	
		M2	3-4-6	6-7	5-7	4-5-6	6	6	4-5	3-5-6-7-8	6	2-9-10	9-10	3	4	4-6	5	4	1-2	
	18	M1	2	4-6-7	1-2-3-5	3-4-6	1-3-4-7	2-3-4-5	4	2-5-9	3-5-6	1-8-9	2-4-6	2-3-4	2-3-4	1-3-4	3	2-4	1-2	
		M2	3-4-6	5-6-7	5-6-7	4-5-6	6	6-7	4-5-6	3-5-6-7-8	3-6	2-9-10	9-10	3-5-6	4-5	4-5-6	3-5	4	1-2	
	19	M1	2	4-6-7	1-2-3-5	3-4-6	1-3-4-7	2-3-4-5	4	2-5-9	3-5-6	1-8-9	2-4-6	2-3-4	2-3-4	1-3-4-5	3	2-4	1-2	
		M2	3-4-6	5-6-7	5-7	4-5-6	6	6-7	4-5	3-5-6-7-8	3-6	2-9-10	9-10	3-5-6	4-5	4-5-6	3-5	4	1-2	

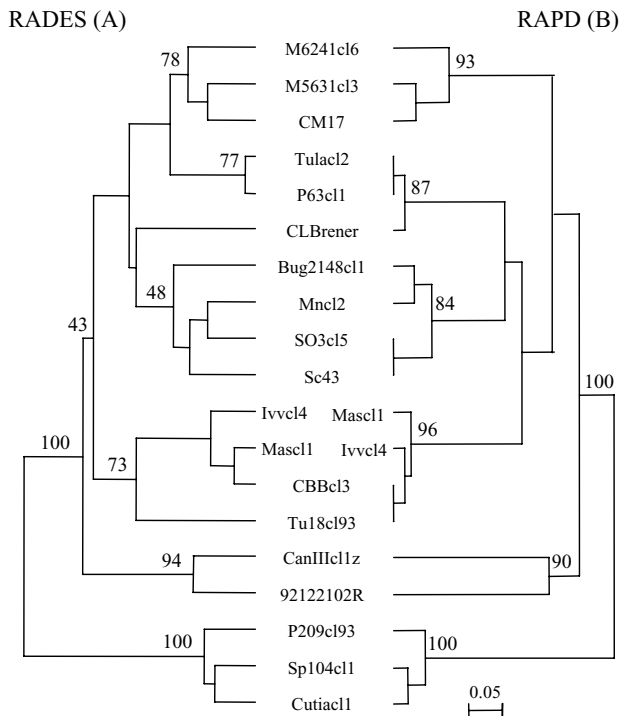

Fig. 3. UPGMA dendrograms constructed from two independent set of markers : RADES (A) by using nine primers and RAPD (B) by using eight other primers. The analysis was performed on the 19 *Trypanosoma cruzi* stocks studied in the present work. The number at the nodes indicate the Bootstrap value of each DTU.

and intragenic recombination generating mosaic genes [11].

Contradictions between these results and the clonal model are only superficial. In fact, the clonal hypothesis does not state that genetic exchange is absent, but rather that it is severely restricted [1,13]. *T. cruzi* still fits this model. The results of Gaunt et al. [11] cast doubt on the lines of evidence for clonality based on departures from Hardy-Weinberg equilibrium, since genetic exchange in *T. cruzi* does not operate through meiosis, and generates aneuploidy. However, for the very reason that diploidy was not a fully ascertained working hypothesis, we have discarded the Hardy-Weinberg analysis for the time being and have taken as circumstantial evidence for clonality only the presence of a strong linkage disequilibrium [2].

A particularly telling case of linkage disequilibrium is the correlation between distinct genetic markers such as MLEE and RAPD, which chiefly concern different parts of the genome. It can be statistically measured by a correlation test (*G* test; [13]). In the extreme case, this strong association leads to very similar or identical phylogenetic trees. Such results were repeatedly observed in *T. cruzi*, for MLEE, RAPD [6,14], microsatellites [27], large and small rRNA subunits and mini-exon genes [28]. Another line of evidence for the scarcity of genetic exchange in *T. cruzi* is historical: genotypes that were isolated more than 20 years ago [29,30], and are still present unchanged over vast geographical areas.

As already observed, in the present study we have recorded a close similarity between MLEE and RAPD data. It is much more unexpected to observe a similar pattern with the RADES results. Indeed, RADES profiles specifically correspond to expressed genes and coding regions, which are bound to undergo, at least for a high percentage of them, selective pressures. The case is different for the usual RAPD technique, which randomly amplifies any part of the genome, including noncoding sequences [17]. When isoenzymes are considered, their polymorphism is considered classically as selectively neutral [15]. It would therefore be conceivable that the RADES polymorphism follows quite different evolutionary patterns. Nevertheless, the agreement between RADES on the one hand, and MLEE and RAPD on the other hand, is close, as illustrated by the fact that the trees generated by the three techniques show similar clustering and individualize the six DTUs previously described within *T. cruzi* [5,6]. Discrepancies are however, visible for the branching orders of the stocks within the DTUs. These phylogenies are therefore very similar, but not identical. These slight discrepancies can be explained by: (i) lack of resolution of the markers used at such microevolutionary levels; (ii) limited sample size; (iii) occasional hybridization events [8–11]. The three hypotheses are not exclusive of each other. The same arguments can explain why some bootstrap values are low in our data (Fig. 2). It is worth noting that when much more stocks and a higher number of MLEE loci and RAPD primers are used, bootstrap values are higher, and the agreement between MLEE and RAPD phylogenies is closer [5,6]. This favours the hypothesis of lack of resolution due to limited size sample and set of markers.

It could be thought that RADES polymorphism is a simple subsample of RAPD polymorphism, since the final step of RADES involves a RAPD amplification. However, this idea is by no means a substantiated fact, nor based on common sense: (a) RAPD also amplifies noncoding regions (about 50% in the genome of *T. cruzi*; El-Sayed, personal communication); (b) RADES amplifies specifically expressed coding genes, whereas RAPD also amplifies those genes that are not expressed at a given time and a given physiological state. Such genes could be numerous. Since PCR is a competition process, and the dominant DNA molecules are preferentially amplified, the idea that RAPD and RADES are redundant is therefore not certain. Also, if this were true, RADES profiles would be simple drawing lots of RAPD profiles, that is to say, the same bands, but with fewer bands. Table 2 clearly shows that this is untrue. Most times, RADES profiles are drastically different from RAPD profiles and they are frequently more complex. However, to definitely discard this putative bias, we carried out the same correlation tests using different sets of primers for RAPD and RADES. The 17 primers were randomly divided into two, nonoverlapping sets and used for RAPD and RADES analyses. Even though the analyses lost power (resulting in half as many primers), (a) the correlation test gave the same level of significance

($P < 10^{-4}$) and (b) RAPD and RADES trees remained very similar, with nearly identical DTU subdivisions (Fig. 3). The only exception was the branching of the CL Brener stock in the RADES tree. This discrepancy again can be explained by lack of resolution, but could be due to the fact that this strain exhibits a hybrid genotype [6], which renders phylogenies less reliable.

In light of recent results [6,8–11], it is indisputable that genetic recombination plays an important role in *T. cruzi* genetic diversity on an evolutionary scale, and it would be misleading to regard this parasite as a purely clonal organism (which has never been proposed). However, the present results confirm that gene flow is severely restricted in this parasite's natural populations. In particular, our results suggest that the impact of gene mosaicism [11] on this parasite's gene polymorphism is limited. If mosaic genes were the rule rather than the exception, this should cloud the agreement between expressed genes on one hand, and other kinds of genetic markers on the other hand, which is refuted by our results.

Our results confirm the robustness of the discrete subdivisions described within the species *T. cruzi* (DTUs I and IIa to IIe). These subdivisions remain reliable units of analysis for molecular epidemiology and experimental and evolutionary studies. Now, the existence of complex sexual processes fully confirmed by the recent experimental study of Gaunt et al. [11] more than ever makes it impossible to equate these subdivisions with real clades. *T. cruzi* undergoes a reticulate evolution. It is apparent that some of its genes have a mosaic structure, and some of its intraspecific subdivisions have several ancestors rather than only one. They therefore do not meet the strict criteria of the definition of clade. Such a pattern is probably more the rule than an exception when pathogenic microbes are involved. The need to bypass this conceptual difficulty is why the concept of DTU has been developed [7].

Work is in progress to analyze and sequence the genes corresponding to RADES bands that appear to be specific of each DTU (Table 2), and to complete the comparison of expressed genes between different physiological states of the parasite.

Acknowledgements

Jenny Telleria was supported by a scholarship from the French government (Institut de Recherche pour le Développement). Two anonymous referees made it possible to improve considerably this paper.

References

- [1] Tibayrenc M, Ward P, Moya A, Ayala FJ. Natural populations of *Trypanosoma cruzi*, the agent of Chagas disease, have a complex multiclonal structure. *Proc Natl Acad Sci USA* 1986;83:115–9.
- [2] Tibayrenc M. Population genetics of parasitic protozoa and other microorganisms. *Adv Parasitol* 1995;36:47–115.
- [3] Souto RP, Fernandes O, Macedo AM, Campbell DA, Zingales B. DNA markers define two major phylogenetic lineages of *Trypanosoma cruzi*. *Mol Biochem Parasitol* 1996;83:141–52.
- [4] Momen H. Taxonomy of *Trypanosoma cruzi*: a commentary on characterization and nomenclature. *Mem Inst Oswaldo Cruz* 1999;94(Suppl 1):181–4.
- [5] Barnabé C, Brisse S, Tibayrenc M. Population structure and genetic typing of *Trypanosoma cruzi*, the agent of Chagas disease: a multilocus enzyme electrophoresis approach. *Parasitology* 2000;120(Pt 5):513–26.
- [6] Brisse S, Barnabé C, Tibayrenc M. Identification of six *Trypanosoma cruzi* phylogenetic lineages by random amplified polymorphic DNA and multilocus enzyme electrophoresis. *Int J Parasitol* 2000;30:35–44.
- [7] Tibayrenc M. Genetic epidemiology of parasitic protozoa and other infectious agents: the need for an integrated approach. *Int J Parasitol* 1998;28:85–104.
- [8] Bogliolo AR, Lauria-Pires L, Gibson WC. Polymorphisms in *Trypanosoma cruzi*: evidence of genetic recombination. *Acta Trop* 1996;61:31–40.
- [9] Carrasco HJ, Frame IA, Valente SA, Miles MA. Genetic exchange as a possible source of genomic diversity in sylvatic populations of *Trypanosoma cruzi*. *Am J Trop Med Hyg* 1996;54:418–24.
- [10] Machado CA, Ayala FJ. Nucleotide sequences provide evidence of genetic exchange among distantly related lineages of *Trypanosoma cruzi*. *Proc Natl Acad Sci USA* 2001;98:7396–401.
- [11] Gaunt MW, Yeo M, Frame IA, et al. Mechanism of genetic exchange in American trypanosomes. *Nature* 2003;421:936–9.
- [12] Barrett MP, Stich A, Lazzari JO, Frascch AC, Cazzulo JJ, Krishna S, Burchmore, RJS, The trypanosomiasis. *Lancet* 2003;362:1469–80.
- [13] Tibayrenc M, Kjellberg F, Ayala FJ. A clonal theory of parasitic protozoa: the population structures of Entamoeba, Giardia, Leishmania, Naegleria, Plasmodium, Trichomonas and Trypanosoma and their medical and taxonomical consequences. *Proc Natl Acad Sci USA* 1990;87:2414–8.
- [14] Tibayrenc M, Neubauer K, Barnabé C, et al. Genetic characterization of six parasitic protozoa: parity between random-primer DNA typing and multilocus enzyme electrophoresis. *Proc Natl Acad Sci USA* 1993;90:1335–9.
- [15] Ayala FJ, Kiger JA. *Modern Genetics*, 2nd ed., Menlo Park, CA: The Benjamin Cummings Publishing Cie, Inc.; 1984. [15].
- [16] Murphy NB, Pelle R. The use of arbitrary primers and the RADES method for the rapid identification of developmentally regulated genes in trypanosomes. *Gene* 1994;141:53–61.
- [17] Welsh J, McClelland M. Fingerprinting genomes using PCR with arbitrary primers. *Nucleic Acids Res* 1990;18:7213–8.
- [18] Ullu E, Tschudi C, Günz A. In: Smith DF, Parsons M, editors. *Frontiers in Molecular Biology—Molecular Biology of Parasitic Protozoa*. Oxford: IRL Press; 1996. 115–133.
- [19] Jaccard P. Nouvelles recherches sur la distribution florale. *Bull Soc vaudoise Sci Nat* 1908;44:223–70.
- [20] Sneath PHA, Sokal RR. *Numerical Taxonomy. The principle and Practice of Numerical Classification*. San Francisco: Freeman; 1973.
- [21] Saitou N, Nei M. The neighbor-joining method: a new method for reconstructing phylogenetic trees. *Mol Biol Evol* 1987;4:406–25.
- [22] Felsenstein J. PHYLIP: phylogenetic Inference Package. Version 3.5c. Department of Genetics, University of Washington, Seattle. 1993.
- [23] Page RD. Treeview: an application to display phylogenetic trees on personal computers. *Comput Appl Biosci* 1996;12:357–8.
- [24] Felsenstein J. Confidence limits on phylogenies: an approach using the bootstrap. *Evolution* 1985;39:783–91.
- [25] Mantel N. The detection of disease clustering and a generalized regression approach. *Cancer Res* 1967;27:209–20.

- [26] Gibson W, Bailey M. Genetic exchange in *Trypanosoma brucei*: evidence for meiosis from analysis of a cross between drug-resistant transformants. *Mol Biochem Parasitol* 1994;64:241–52.
- [27] Oliveira RP, Broude NE, Macedo AM, et al. Probing the genetic population structure of *Trypanosoma cruzi* with polymorphic microsatellites. *Proc Natl Acad Sci USA* 1998;95:3776–80.
- [28] Brisse S, Verhoef J, Tibayrenc M. Characterisation of large and small subunit rRNA and mini-exon genes further supports the distinction of six *Trypanosoma cruzi* lineages. *Int J Parasitol* 2001;31:1218–26.
- [29] Miles MA, Souza A, Povoá M, et al. Isozymic heterogeneity of *Trypanosoma cruzi* in the first autochthonous patients with Chagas' disease in Amazonian Brazil. *Nature* 1978;272:819–21.
- [30] Tibayrenc M, Miles MA. A genetic comparison between Brazilian and Bolivian zymodemes of *Trypanosoma cruzi*. *Trans R Soc Trop Med Hyg* 1983;77:76–83.